

## *Firing Pin Protrusion Gage*

P/N 1005-200-12

***Make certain that the firearm is unloaded before performing any work.***

*The Badger Ordnance Firing Pin Protrusion Gage can be used on any firearm with a breech face diameter of .375" or larger.*

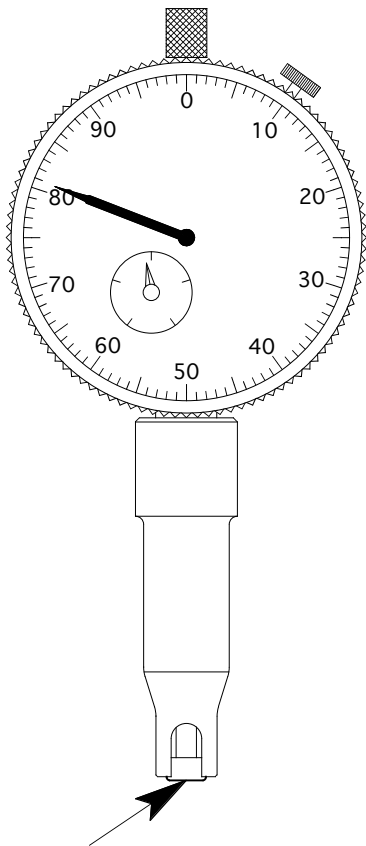

*Plunger tip should protude a little, you will zero it in the next step.*

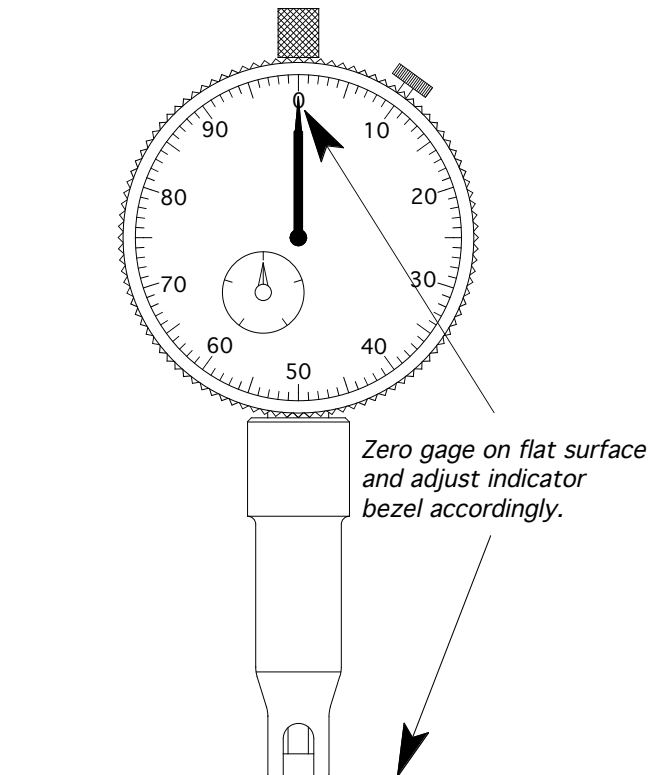

*Zero gage on flat surface and adjust indicator bezel accordingly.*

*The gage has a notch that lets you measure bolts with a spring Ejector installed.*

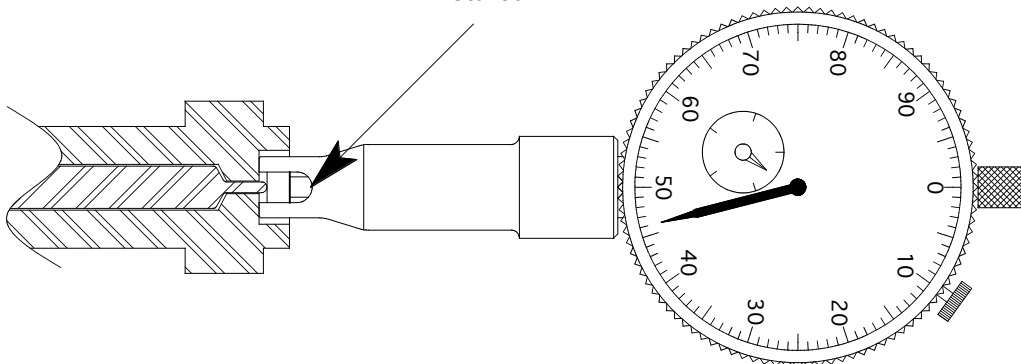

*With the firing pin in the "fired Position," place the gage against the bolt face. Take the direct reading. Repeat 2 or 3 times to make certain the reading is correct.*